



ProFlame™ Integrated Flame Scanner

Model ZPF-130



The ZEECO® ProFlame™ integrated flame scanner revolutionizes the industry by providing reliable flame detection and instant flame status for safer operation. **Easy to configure, simple to set up, the Model ZPF-130 is uniquely designed for use in non-hazardous (safe) areas.**

Design Features and Benefits

- Compact and exceptionally reliable
- State-of-the-art digital signal processing for easy flame analysis
- Easily configurable frequency and gain settings for simple set-up
- Intuitive display to assist in troubleshooting
- Dual signal channel with electronic self-check for SIL3 applications
- Aiming feature reduces commissioning time when sighting the flame scanner
- Durable housing for a variety of operating environments
- Low power consumption with a 24V dc supply
- Reliable 4-to-20 mA flame intensity output

Operating Environment

- Temperature: -20°C (-4°F) to +60°C (140°F)
- Relative humidity: 0% to 95% non-condensing
- Environmental protection rating: IP 67, NEMA 4X
- Vibration fatigue limit: 2 g (function tested to 5 g)
- Weight: 1.3 lbs (0.6 kg)
- Mounting: 1" NPT M (BSP available), integral sealing window and noise/heat barrier
- Housing material: aluminum, polished finish
- Cable: quick disconnect, 8 conductor cable



BURNERS



FLARES



INCINERATORS



PARTS & SERVICE

Model ZPF-130

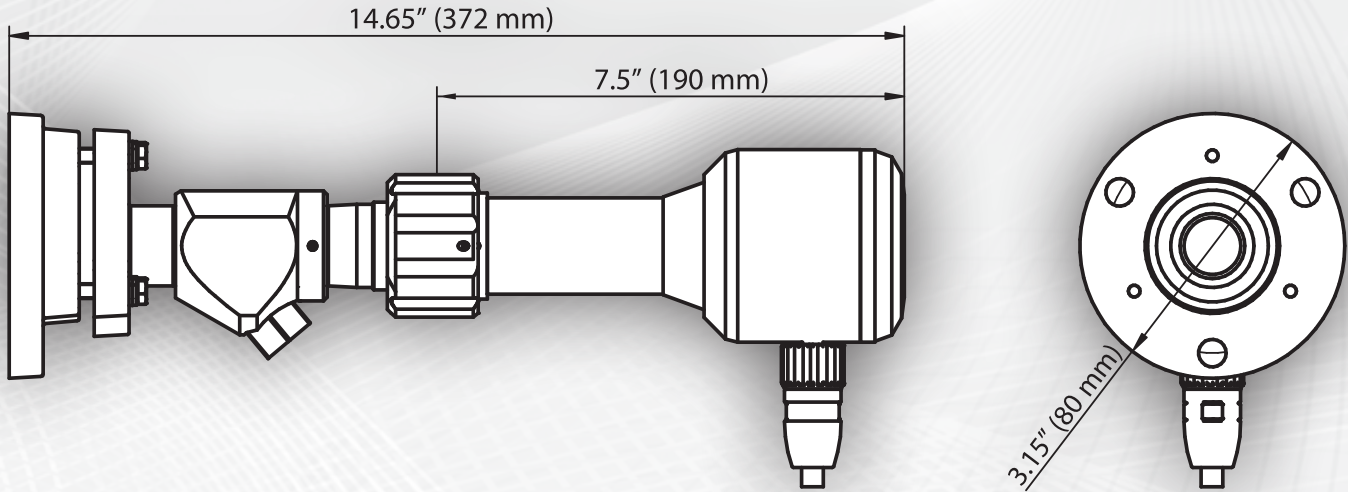

Operating Parameters - Input

Input voltage

Supply voltage: 24V dc ± 20%, protection class III

Power consumption: 4 W

Purge air

Cool, dry, clean air: 5 scfm (142 l/min) at 5" wc (12.5 mbar) above windbox or furnace pressure (sight tube exit point), ≤ 38°C (100°F) at wye fitting

Operating Parameters – Output

Output relay: SPDT, Flame-On is the N.O. contact and Flame-Off is the N.C. contact

Contact rating: 48V dc at 0.5 A

Flame intensity output: 4 to 20 mA referenced to 24V dc common; 220Ω at 6.6V (±2%)

Flame status indication: Flame-On LED, Flame-Off LED, Flame intensity bar graph

ZEECO® combustion and environmental solutions are designed and manufactured to comply with applicable local and international standards as defined by our customers.



REGISTERED ISO 9001: 2008

CERTIFICATION APPLIES TO ZEECO HEADQUARTERS ONLY.

Zeeco Global Headquarters

22151 East 91st Street

Broken Arrow, Oklahoma 74014 USA

Phone: +1 918 258 8551

Fax: +1 918 251 5519

E-mail: sales@zeeco.com

Zeeco.com

ZEECO® is a registered trademark of Zeeco, Inc. in the U.S.

• ZEECO office, affiliate, sales, representative, or third party representative/licensee offices.

© COPYRIGHT 2015 - ZEECO, INC. ALL RIGHTS RESERVED

